

# 1.1 Schlüter®-SCHIENE



FLOOR COVERING PROFILES

FOR RELIABLE EDGE PROTECTION

## Application and Function

Schlüter®-SCHIENE is an extruded profile that finishes and protects the edges of tiled coverings, as well as other surfacing materials.

Applications include: transitions between different surface coverings (e.g. tile to carpet); dado coverings; edge protection at expansion joints; decorative edging for stairs; as well as a finishing profile for all types of surfaces, such as carpet, parquet, laminates, natural stone coverings, or cold cured resin coverings.

The profile's unique design combines specific angle positions and material wall thicknesses to transmit point loads into the substrate and surface covering, thus protecting the covering's edges against damage.

The joint spacer, which is integrated in profiles higher than 6 mm, establishes a defined joint cavity between the tile and the profile. The anchoring leg of Schlüter®-SCHIENE, in all material types, can be punched with a special radius perforation "R" so that the profile can be used to form curves.

## Material

Schlüter®-SCHIENE is available in the following materials: brass (-M), aluminium (-A), anodised aluminium (-AE), stainless steel (-E), and brushed stainless steel (-EB).

## Material Properties and Areas of Application:

In special cases, the suitability of a proposed type of material must be verified, based on anticipated chemical, mechanical and/or other stresses.



Schlüter®-SCHIENE-M, in solid brass, sustains high levels of mechanical stress, e.g. as edge protection for movement joints in coverings exposed to industrial traffic. Brass is resistant to most chemicals used in tiled environments. Solid brass that is exposed to air will oxidize, resulting in a natural patina. If exposed to moisture or aggressive substances, heavy oxidation and spotting may occur.

Schlüter®-SCHIENE-E is roll formed using V2A (material 1.4301) or V4A (material 1.4404) stainless steel. Therefore, the profile's contour differs slightly from the extruded brass or aluminium profile.

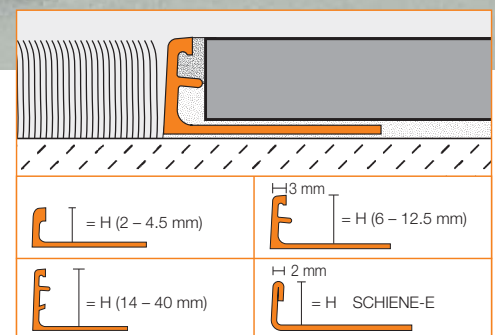



Schlüter®-SCHIENE-E can sustain high mechanical stresses and is especially well suited for applications requiring resistance against chemicals and acids, e.g. in the food industry, in breweries, dairies, commercial kitchens, public swimming pools and hospitals. Depending on the anticipated chemical exposure, alloy materials 1.4301 or 1.4404 may be chosen.

Schlüter®-SCHIENE-A, in aluminium, must be tested to verify its suitability if chemical stresses are anticipated. Cementitious materials, in conjunction with moisture, become alkaline. Since aluminium is sensitive to alkaline substances, exposure to the alkali (depending on the concentration and time of exposure) may result in corrosion (aluminium hydroxide formation). Therefore, it is important to remove adhesive or grout residue from visible surfaces. In addition, ensure that the profile is solidly embedded in the setting material and that all cavities are filled to prevent the collection of alkaline water.



Schlüter®-SCHIENE-AE is made of clear satin anodised aluminium. The anodised layer creates a finish that retains a uniform appearance during normal use. The surface, however, is susceptible to scratching and wear and may be damaged by tile adhesive, mortar, or grouting material. Therefore, setting materials must be removed immediately. Otherwise, the description regarding aluminium applies.

### Installation

1. Select Schlüter®-SCHIENE according to tile thickness.
2. Trowel tile adhesive over the area that forms the perimeter of the tiled covering.
3. Press the perforated anchoring leg of the Schlüter®-SCHIENE into the tile adhesive and align.
4. Trowel additional adhesive over the perforated anchoring leg to ensure full coverage.
5. Solidly embed the tiles so that the tiled surface is flush with the top of the profile (the profile should not be higher than the tiled surface, but rather up to approx. 1 mm lower).
6. The tile is set to the lateral joint spacer, which ensures a uniform joint of 1.5 mm. With the stainless steel profiles, leave a space of approximately 1.5 mm.
7. Fill the joint completely with grout.

### Maintenance

Schlüter®-SCHIENE does not require any special maintenance. Oxidation films on brass or aluminium may be removed with a common polishing agent; however, they do reoccur. Damaged anodised finishes may only be repaired by recoating. Stainless steel surfaces develop a sheen when treated with a chrome polishing agent, etc. Stainless steel surfaces exposed to the environment or aggressive substances should be cleaned periodically using a mild household cleaner. Regular cleaning maintains the neat appearance of stainless steel and reduces the risk of corrosion. All cleaning agents must be free of hydrochloric and hydrofluoric acid.

Avoid contact with other metals such as steel, since this can cause extraneous rust. This also includes tools such as trowels or steel wool, i.e. tools used to remove mortar residue.



**Product overview:**

**Schlüter®-SCHIENE**

M = brass / A = aluminium / AE = anodised aluminium  
 Length supplied: 2.50 m

Material	M	A	AE
H = 2 mm		•	•
H = 3 mm	•	•	•
H = 4.5 mm	•	•	•
H = 6 mm	•	•	•
H = 7 mm		•	•
H = 8 mm	•	•	•
H = 9 mm	•	•	•
H = 10 mm	•	•	•
H = 11 mm	•	•	•
H = 12.5 mm	•	•	•
H = 14 mm		•	•
H = 15 mm	•	•	•
H = 16 mm	•	•	•
H = 17.5 mm	•	•	•
H = 20 mm	•	•	•
H = 21 mm		•	•
H = 22.5 mm	•	•	•
H = 25 mm	•	•	•
H = 27.5 mm		•	•
H = 30 mm	•	•	•

Length supplied: 1.00 m

Material	M	A	AE
H = 4.5 mm	•	•	•
H = 6 mm	•	•	•
H = 8 mm	•	•	•
H = 10 mm	•	•	•
H = 12.5 mm	•	•	•
H = 15 mm	•	•	•

**Schlüter®-SCHIENE-E**

E = stainless steel / EV4A = stainless steel 1.4404 = V4A /  
 EB = brushed stainless steel V2A  
 Length supplied: 2.50 m

Material	E	EV4A	EB
H = 2 mm	•		
H = 3 mm	•		
H = 4.5 mm	•	•	
H = 6 mm	•	•	•
H = 7 mm	•		
H = 8 mm	•	•	•
H = 9 mm	•		
H = 10 mm	•	•	•
H = 11 mm	•		
H = 12.5 mm	•	•	•
H = 14 mm	•		
H = 15 mm	•	•	
H = 17.5 mm	•	•	
H = 20 mm	•	•	
H = 22.5 mm	•	•	
H = 25 mm	•	•	
H = 30 mm	•	•	

Length supplied: 1.00 m

Material	E
H = 6 mm	•
H = 8 mm	•
H = 10 mm	•
H = 12.5 mm	•



**Text template for tenders:**

## Supply

\_\_\_\_\_ per metre Schlüter®-SCHIENE as a transition and edge protection profile

- M = brass
- A = aluminium
- AE = anodised aluminium

with a trapezoid perforated anchoring leg connected to an 87° angled finishing section, which widens to a sloped top flange and features an integrated joint spacer to create the joint cavity . . .

\_\_\_\_\_ per metre Schlüter®-SCHIENE-E as a transition and edge protection profile

- E = stainless steel 1.4301 (V2A)
- E V4A = stainless steel 1.4404 (V4A)
- EB = brushed stainless steel 1.4301 (V2A)

with trapezoid perforated anchoring leg, angled (87°) wall section, and sloped top flange, made of roll formed stainless steel . . .

Profile height: \_\_\_\_\_ mm

Art.-No.: \_\_\_\_\_

- in individual lengths of \_\_\_\_\_ m
- in various lengths, as required
- as edge protection for individual fields of covering with adjacent expansion joints
- as covering surround
- to position
- according to detail drawing

. . . and install according to manufacturer's application and working instructions.

Material: \_\_\_\_\_/m

Labour: \_\_\_\_\_/m

Total: \_\_\_\_\_/m